

GMX 25, 30 and 40 Disc Brake Caliper

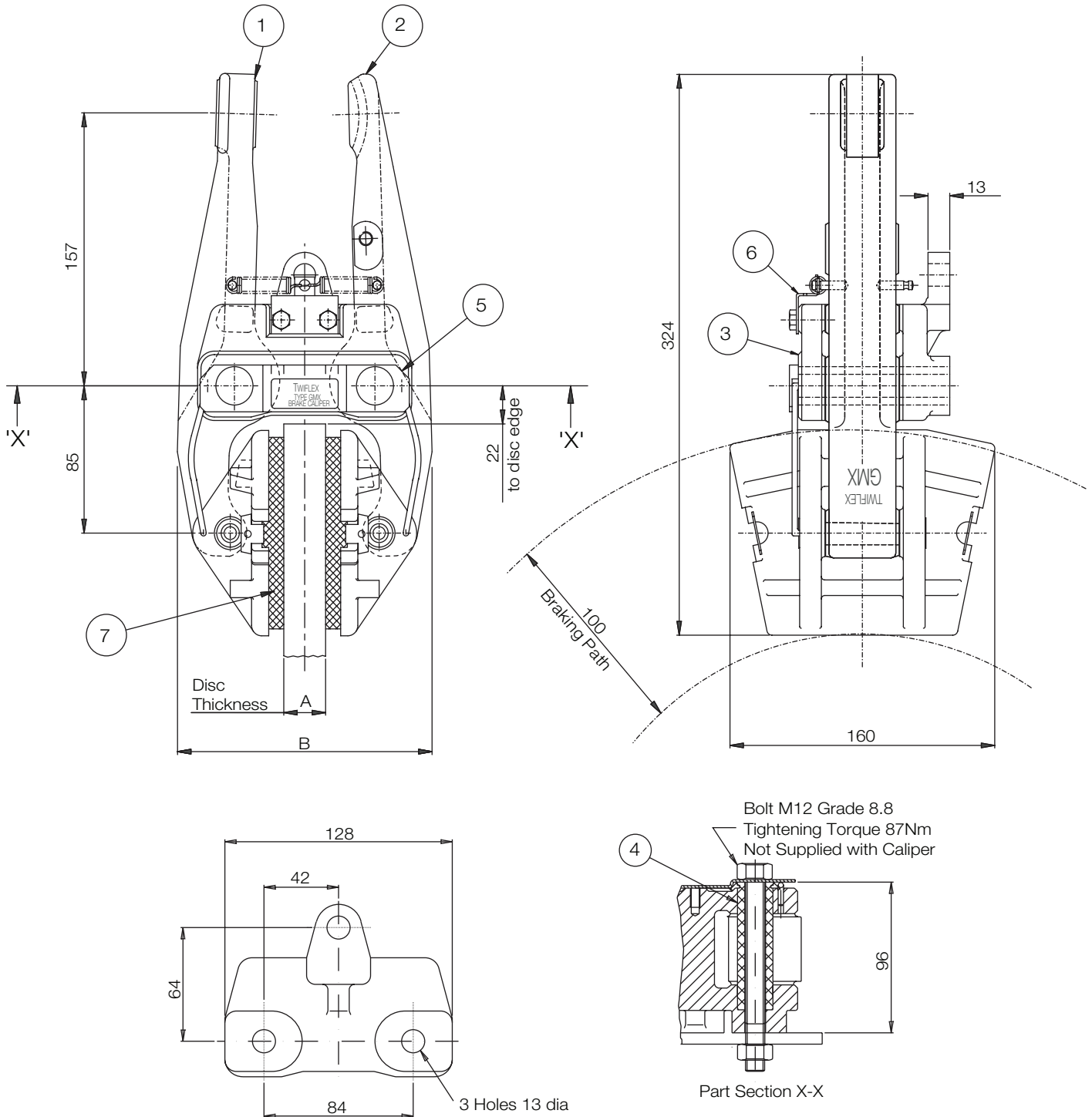

Dimensions in mm			
Caliper	Part No.	A	B
GMX25	6780901	25.4	152
GMX30	6781251	30	155
GMX40	6781246	40	162

Weight of Caliper = 9.22kg (2 pads)
 Total pad area = 133cm² (2 pads)
 Pad material = Moulded asbestos-free high friction material
 The standard GMX series brake caliper is supplied as a right-hand assembly (as shown above).
 Left-hand assembly can be supplied on request.

Twiflex Disc Brakes must be used with Twiflex asbestos free brake pads.
 The use of any other brake pads will invalidate the warranty.
 Twiflex Limited reserves the right to modify or change the design without prior notice.

GMX 25, 30 and 40 Disc Brake Caliper

General Description

The Twiflex GMX25, GMX30 & GMX40 disc brake calipers are used with brake discs of 25.4, 30 & 40mm thickness respectively. They may be used with any of the series of actuators listed below. Normally one or two units will be used per disc but the number may be increased, depending on disc size.

Thruster	Description	Data Sheet	Maximum Braking Force
A	Pneumatically applied spring released	2601	6.9
B	Pneumatically applied spring released	2602	11
D	Pneumatically applied spring released	2603	3.6
E	Pneumatically applied spring released	2604	0.74
G	Pneumatically applied spring released	2605	1.9
H	Mechanically applied hand operated	2606	8.3
K	Spring applied pneumatically released	2607	2.15, 4.3 and 6.4
L	Spring applied pneumatically released	2608	2.15, 4.3 and 6.4
XS	Spring applied pneumatically released	2609	6.8, 11.2 and 14.3
XSH	Spring applied hydraulically released	2610	6.8, 11.2 and 14.3
W	Mechanically applied hand operated	2611	2.68
EMX	Spring applied electrically released	2612	6.1

The brake units can be positioned at any angle around the periphery of the disc, but ideally they should be mounted horizontally (in 3 or 9 o'clock positions) in relation to the disc.

If a caliper is mounted at an angle of more than about 10° from the horizontal it should be fitted with an inclined mounting kit or equalising link. This applies also to calipers used on vertical shaft installations.

Discs:

A range of standard discs of 25.4mm thickness are available from Twiflex see Data Sheet DS0501. Minimum disc diameter for the GMX caliper is 610mm

Controllers:

Standard Twiflex Controllers are available for single or multi-caliper installations for use with electric, pneumatic and hydraulic signalling systems.

Pad replacement in air applied calipers:

To replace the pads, secure the installation to ensure safety. Straighten tabs at each end of the brake pads, and remove worn pads. Clean disc and the pad recesses in the shoes with a suitable cleaning agent such as white spirit. Fit new pads, and bend tabs through 90° so as to hold pads in position, the pad should be free to move sideways.

Pad replacement in spring applied calipers:

To replace the pads, secure the installation to ensure safety.

Slacken the two locknuts holding the thruster, and screw back the push rod to create space between pad and disc.

Straighten tabs at each end of the brake pads, and remove worn pads. Clean disc and the pad recesses in the shoes with a suitable cleaning agent such as white spirit. Fit new pads, and bend tabs through 90 deg. so as to hold pads in position, the pad should be free to move sideways.

Refit the thruster as described in the relevant data sheet

AVAILABLE SPARES				
Caliper		GMX25	GMX30	GMX40
Item	Component	Part No.	Part No.	Part No.
1	Arm Assembly-Thruster	6600182	660238	6600239
2	Arm Assembly- Slotted	6600181	6600241	6600242
3	Caliper Base	8030026	8030026	8030026
4	Pivot Pin	7952383	7952383	7952383
5	Retaining Plate	7951480	7951480	7951480
6	Spring Anchor Plate	7951501	7951501	7951501
7	Pad Assembly (2 required)	7080139-Z	7080139-Z	7080139-Z
	Spring Kit	7903113	7903113	7903113
	Inclined Mounting Kit	7903069	7903069	7903069

For bedding-in and conditioning procedures see publication M1060
Health and Safety data sheet reference to DS 0500